

TUNGUS®



Istochnik Plus, closed joint stock company
659322, 1, Socialisticheskaya St., Biysk, Altay region, Russia,
Tel.: (3854) 30-19-32, 30-58-59

www.antifire.org

antifire@inbox.ru



ГОСТ Р ИСО 9001



**POWDER FIRE-EXTINGUISHING MODULE
MPP(N)-0.65-I-GE-U2
Passport and
Manual instructions**



1 PURPOSE

1.1 Powder fire-extinguishing module MPP(N)-0.65-I-GE-U2 (hereinafter referred to as the MPP) is intended for automatic extinguishing of fires class A (solids), B (liquids), C (gases) and E (electrical equipment under tension without taking into account the value of firefighting powder discharge voltage).

MPP can be equipped with electronic activation device during the usage of which a module obtains a function of self-activation and can be used as an autonomous powder fire-extinguishing mean.

1.2 The MPP is not designed to extinguish the ignition of substances that can burn without air access.

1.3 The MPP is intended to extinguish both the local and volume fire in the room.

1.4 The MPP can be performed in normal version with operating temperatures of minus 50°C to plus 50°C, in special version at operating temperatures of minus 60°C to plus 90°C, or in wide temperature operation range of minus 60°C to plus 125°C. MPP operation is allowed under relative humidity not more than 95% when temperature is 25°C.

1.5 The fire extinguishing powder is ejected by the gas generated with a cold gas source CGS-0.65(M) SIAV 066614.025.000 TU.

1.6 The MPP is a reused-product.

1.7 Examples of the MPP marking (model) records when ordered:

- MPP (N)-0.65-I-GE-U2 TU 4854-011-54572789-06 in normal version at temperatures of minus 50°C to plus 50°C;
- MPP (N-T)-0.65-I-GE-U2 TU 4854-011-54572789-06 in special version at operating temperatures of minus 60°C to plus 90°C;
- MPP (N-T1)-0.65-I-GE-U2 TU 4854-011-54572789-06 in wide temperature operation range of minus 60°C to plus 125°C.

2 TECHNICAL CHARACTERISTICS

2.1 Technical characteristics of the MPP are given in Table 1.

Table 1

Name	Value
1 Case capacity, litres	0.65 ^{+0.07}
2 Dimension, mm, not more than:	
- height	130
- length	230
3 Total weight of the MPP, kg, not more than	3
4 Fire extinguishing powder ISTO-1 weight, TU 2149-001-54572789-00, kg	0.49 ^{+0.05}

ANNEX A

(obligatory)

THE RESULTS OF TECHNICAL MAINTENANCE

Table A.1 - Information about reloading, reexamination

Date	Work to do	Executive (company, name)	Executive's signature and stamp

The alterations not given in the present passport and not affecting the principal technical characteristics, dimension and connecting sizes can be introduced into the module design.

11 CERTIFICATE OF ACCEPTANCE AND SALE

The fire extinguishing module

MPP(N)-0.65-I-GE-U2 MPP(N-T)-0.65-I-GE-U2

MPP(N-T1)-0.65-I-GE-U2

(tick off the necessary)

corresponds to the requirements of TU 4854-011-54572789-06 and is considered to be fit for use.

Batch No _____

Manufacturing date _____
(month, year)

Inspector signature and stamp _____

Sold _____
(name of the Seller)

Sale date _____

Shop stamp

Table 1 to be continued

Name	Value
5 MPP fast action (time from the moment of sending impulse to a triggering element of the MPP to the moment of ejecting extinguishing powder out of the module, sec.	of 3 to 8
6 Operating time (time of ejecting extinguishing powder), sec., not more than	1
7 Pressure of membrane rupture, MPa	2.0...2.4
8 The MPP fire extinguishing ability:	
8.1 Surface to be protected (S), Class A, m ²	1.2
8.2 Volume to be protected (V), Class A, m ³	2.4
8.3 Surface to be protected (S), Class B, m ²	1.2
8.4 Volume to be protected (V), Class B, m ³	1.2
9 Maximum rank of the model fire site, Class B, when extinguishing at an open area or in a room from the height (H) up to 3 m	8B ^{*)}
10 Circuit characteristics of electric triggering unit:	
- safe current of testing circuit, A, not more than	0.03
- operating current, A, not less than:	
a) normal version of the MPP	0.12
b) special version of the MPP	0.15
- electric resistance, Ohm	8...16
11 Irregularity coefficient of spraying powder K ₁ (SP 5.13130.2009)	1.0
NOTE: ^{*)} – according to GOST R 53286-2009 model site, rank 8B, is the surface of burning petrol (benzine) as a circle 0.56m in diameter having the surface area 0.25m ² .	

3 COMPLETENESS OF SET

3.1 The MPP set to be supplied consists of:

- the module MPP TU 4854-011-54572789-06 –1 item;
- Passport and Manual instructions - 1 copy;
- MPP package –1 item.

4 DESIGN AND PRINCIPLE OF OPERATION

4.1 The MPP design

4.1.1 The MPP (see Figure 1) consists of a case **1** where fire extinguishing powder (OP) **2** and cold gas source (CGS) **3** with electric triggering element **4** are placed. In the front part of the case there is a nozzle-sprayer **5**, the output hole of it is closed by membrane **6**. The module has grounding clamp **7**.

The MPP case side is fitted with support **8** to fasten to the bearing surface (wall, ceiling, floor, etc.).

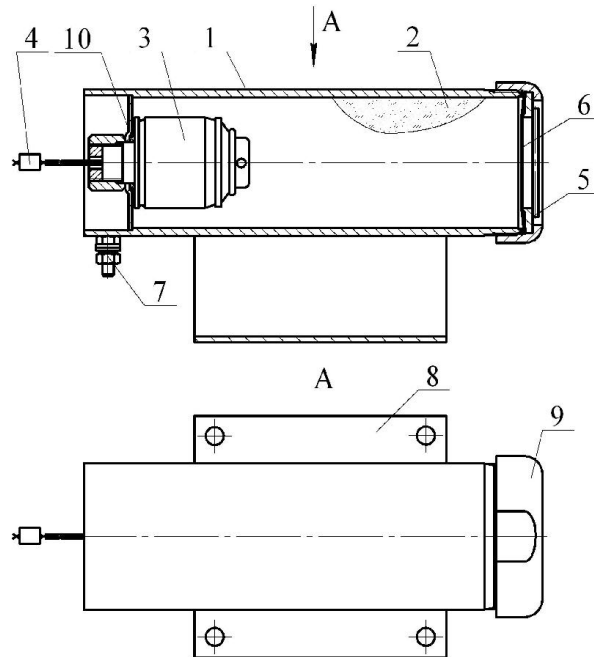

Figure 1

4.1.2 The MPP actuates with the help of current impulse that can be generated by:

- receiving/control, fire alarm, and safeguard devices;
- manual start button;
- self-contained signaling-and-triggering devices (for example, signaling-and-triggering independent automatic device for fire extinguishing setups USPAA-1 TU 4371-032-00226827-99, signaling-and-triggering device USP-101 TU 4371-004-21326303-96).

9.5.2 After launching make sure that the premises are ventilated till safe concentration or enter using isolating protective breath means, draw CGS from the clamp using thermo protective gloves, and then utilize by means of taking to scrap metal.

10 WARRANTY

10.1 The factory-manufacturer guarantees the correspondence of the MPP to the requirements of technical specification if the Customer observes operation, transportation and storage conditions.

10.2 Fixed service life is stated to be:

- not more than 10 years for MPP(N)-0.65-I-GE-U2;
- not more than 5 years for MPP(N-T)-0.65-I-GE-U2,
MPP(N-T1)-0.65-I-GE-U2

and is estimated from the date of accepting the MPP by Quality Department of the factory-manufacturer.

10.3 The factory-manufacturer is not responsible for:

- misoperation if the owner does not observe operation rules;
- negligent storage and transportation of the MPP;
- passport loss;
- after performing reexamination, reloading the MPP under item 7.2 if they were not carried out at the factory-manufacturer;
- expiration of the service life stated from the date of accepting the MPP by Quality Department of the factory-manufacturer.

7.3 The delivery set for MPP reloading:

- CGS-0.65 (M)-01 SIAV 066614.025.000 TU for MPP of normal version; CGS-0.65 (M)-02 SIAV 066614.025.000 TU for MPP of special version, or CGS-0.65 (M)-06 SIAV 066614.025.000 TU for MPP of wide temperature operation range (see item 3 on Figure 1) – 1 item;

- rubber ring 020-026-36 GOST 9833-73 (see item 9 on Figure 1) – 1 item;

- fire-extinguishing powder ISTO-1 TU 2149-001-54572789-00 (see item 2 on Figure 1) – 0.5 kg;

- membrane of SIAV 634233.007.005 drawing (see item 6 on Figure 1) – 1 item.

7.4 After MPP checking and reloading notes are made on MPP case (with a label or ticket fastening) and in MPP manual (See Annex A).

8 STORAGE AND TRANSPORTATION

8.1 The MPP transportation and storage conditions should meet the requirements of OG-4 GOST 15150-69.

8.2 The MPP transportation in the factory packing at temperatures of minus 50°C to plus 50°C is allowed by all kinds of transport according to the rules of transporting the goods by this kind of transport and taking into account transport conditions – harsh environment (G), GOST 23170-78.

8.3 When stored and transported the MPP, conditions preventing them from mechanical damage, direct sunlight, rainfalls and aggressive media should be provided.

9 MPP UTILIZATION AFTER FIXED SERVICE LIFE EXPIRATION

9.1 Utilization works should be made by MPP factory-manufacturer or in organizations having a license for this kind of activity.

9.2 Disassemble MPP.

9.3 MPP frame utilization is made by means of taking to scrap metal.

9.4 Firefighting powder utilization is made according to paragraph 5.7 requirements.

9.5 CGS utilization should be made according to the following instructions.

9.5.1 Actuate CGS in premises equipped with supply-and-exhaust ventilation. For this purpose CGS is placed in a clamp, connected to a direct current power source, which is correspondent to p. 10 or p. 11 of Table 1. The launch is made distantly without any people inside.

4.2 Operation

4.2.1 After sending electric pulse to the outputs of electric triggering unit 4, the CGS 3 generates gas which makes fire-extinguishing powder 2 loose and creates pressure inside the MPP case to rupture membrane 6 and eject through nozzle-sprayer 5 the jet of fire-extinguishing powder into the zone of burning.

5 SAFETY MEASURES

5.1 The staff who was allowed to operate the MPP should study this Passport and observe its requirements.

5.2 It is not allowed:

- keeping the MPP near heat sources;
- effecting rainfalls, direct sunlight, aggressive media, and moisture on the MPP;

- shocking the case and the CGS;

- dropping from the height more than 2 m;

- dismantling the MPP, except for maintenance work according to Section 7 of the present Passport;

- operating the MPP with damaged case (dents, cracks, through holes);

- performing of any fire tests without experimental works program concordance or in case of absence of company-manufacturer representative.

5.3 Before connecting the module, the output ends of the triggering unit should be closed by twisting not less than twice and sealed. Connect the MPP only after its grounding. Electric safety while assembling the MPP should be provided by meeting the requirements PUE, PTE, PTB and PZSE.

5.4 Loading, reloading, and technical maintenance should be carried out in the rooms specially equipped and designed for it at the MPP factory-manufacturer or in organizations having a license for such kind of activity.

5.5 After detecting the module defects (dents, cracks, through holes) during the operation or after its service life, the module should be sent to the factory-manufacturer or utilized according to p. 9.

5.6 While operating the module is fire- and explosion-proof.

5.7 Fire extinguishing powder has no harmful effect on the body and clothes of people, does not cause damage to property and is easy-to-remove. After MPP actuation to remove the combustion products and fire extinguishing powder in the air it is necessary to use general ventilation. It is allowed to apply mobile ventilations sets for this purpose. The powder fell is removed by vacuum cleaner, dry rag followed by wet cleaning. Extinguishing powder waste utilization should be made according to the instruction: “Utilization and Regeneration of Fire Extinguishing Powders”, Moscow: VNIPO, 1988.

5.8 CGS utilization after actuation should be made by means of device taking to scrap metal.

5.9 The bearing construction which the MPP is fastened to, should sustain the impulse load from the module kickback at the moment of fire-extinguishing powder ejecting.

6 PREPARATION OF THE MPP TO OPERATION, LAYOUT AND MOUNTING

6.1 Unpack the MPP, and examine the integrity of case and membrane.

6.2 Fasten the MPP on the bearing surface (wall, ceiling, and floor) in any place of the volume to be protected. The MPP orientation in the volume protected can be quite different: from the horizontal position to vertical one with nozzle-sprayer down. The holes locations to fasten the MPP are shown in Figure 2.

6.3 Calculate the necessary number of modules in the volumes protected in accordance with Section 9 of SP 5.13130.2009.

6.4 While protecting separate surface parts, i.e. at local protection in rooms or under shelter at the height of installation (H) to 3 m, the local surface area equals 0.25 m^2 and is a circle 0.56 m in diameter.

6.5 The configuration of powder spraying and the area image, where smothering is achieved, are given in Figure 3 and in Table 2.

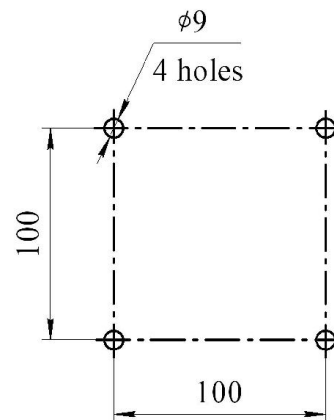

Figure 2

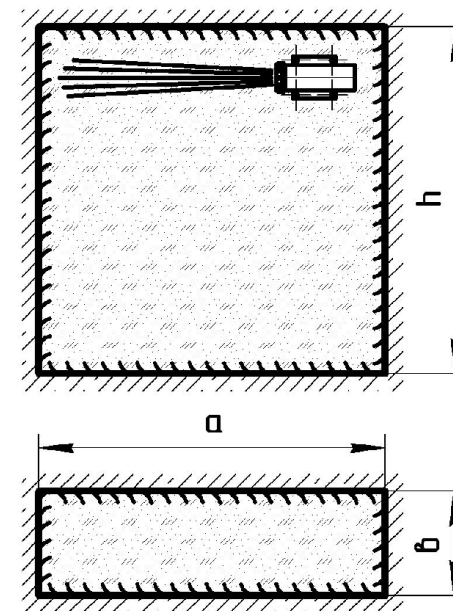

Figure 3

Table 2

Parameters	Class A	Class B	
S, m²	1.2	1.2	-
V, m³	2.4	1.2	1.2
a, m	2.0	2.0	1.0
b, m	0.6	0.6	0.6
h, m	2.0	1.0	2.0

7 MAINTENANCE

7.1 Special technical maintenance within the stated service life is not required. Examine the integrity of the disk (membrane) closing the MPP nozzle-sprayer and the MPP grounding available **once a quarter**. If the disk (membrane) is not intact (damage, holes of puncture, cracks), replace the module.

7.2 Reloading after operating the MPP should be carried out by the MPP factory-manufacturer or in organizations having a license for this kind of activity.